

FLORENCE 4.1/6L DUAL

27 3/16" x 14 3/4" x 30 1/8" Toilet



OPTIONS

COLOR(S)

White

FEATURES

- Powerful siphonic flushing system reduces clogs and backups
- Dual-flush system allows users to choose between partial and full flushes, helping to save water and reduce water bills
- Easy-to-clean and stain-resistant bright white lustrous porcelain finish maintains its appearance over time
- Integrated Soft close and removable close seat for smooth and silent operation and easy cleaning

ATTRIBUTES

- Installation Type : Floor-Mounted
- Material : Porcelain
- Residential Warranty : 5
- Commercial Warranty : 1 Year



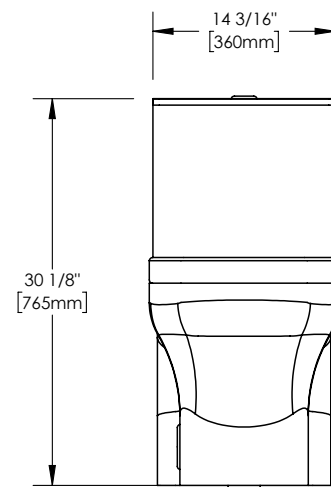
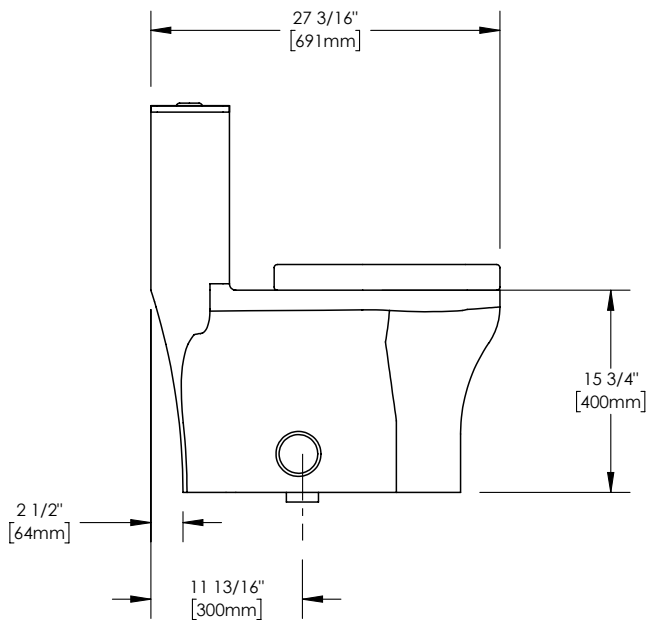
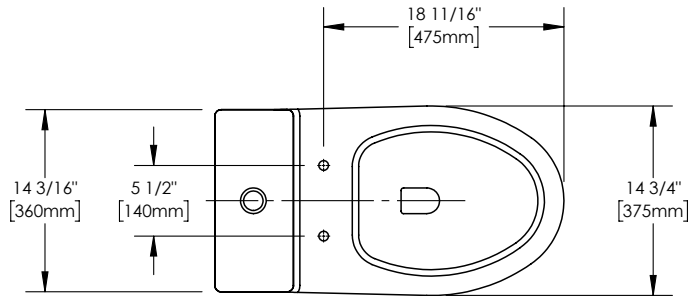

Wood support design may vary.
All dimensions are approximate.
Structure measurements must be verified
against the unit to ensure proper fit.



TECHNICAL SPECIFICATIONS

27 3/16" x 14 3/4" x 30 1/8" Toilet

DIMENSIONS

PRODUCT LENGTH	PRODUCT WIDTH	PRODUCT HEIGHT	WEIGHT	SHIPPING LENGTH
27 3/16"	14 3/4"	30 1/8"	97 Lbs	29 1/2"
SHIPPING WIDTH	SHIPPING HEIGHT	MAP PERFORMANCE RATING		
16"	31"	1000 + g		

Project:

Contractor:

Representative:

Date:

Tel:

Notes:
