



Produits Neptune

INSTALLATION INSTRUCTIONS

GUIDE D'INSTALLATION

GUÍA DE INSTALACIÓN

FOR RIGHT AND LEFT SIDE SHOWER KIT INSTALLATION

POUR INSTALLATION D'ENSEMBLE DE DOUCHE CÔTÉ DROIT ET GAUCHE

PARA LA INSTALACIÓN DE CONJUNTO DE DUCHA DEL LADO DERECHO E IZQUIERDO

MODEL □ **MODÈLE** □ **MODELO**
Solani Sliding shower door
Porte de douche coulissante Solani
Puerta corrediza de ducha Solani
220438 □ **220439**



Read all instructions carefully before proceeding.

Lire attentivement toutes les instructions avant de commencer l'installation.

Leer detenidamente todas las instrucciones antes de comenzar la instalación.

SAVE THIS GUIDE FOR FUTURE REFERENCE.

CONSERVER POUR UN USAGE ULTÉRIEUR.

CONSERVE ESTE MANUAL COMO REFERENCIA.

IMPORTANT □ Record the serial number

IMPORTANT □ Noter le numéro de série

IMPORTANTE □ Registre el número de serie

Serial number □ Numéro de série □ Número de Serie

PARTS
AND COMPONENTS

PIÈCES
ET COMPOSANTES

PIEZAS
Y COMPONENTES



Produits Neptune

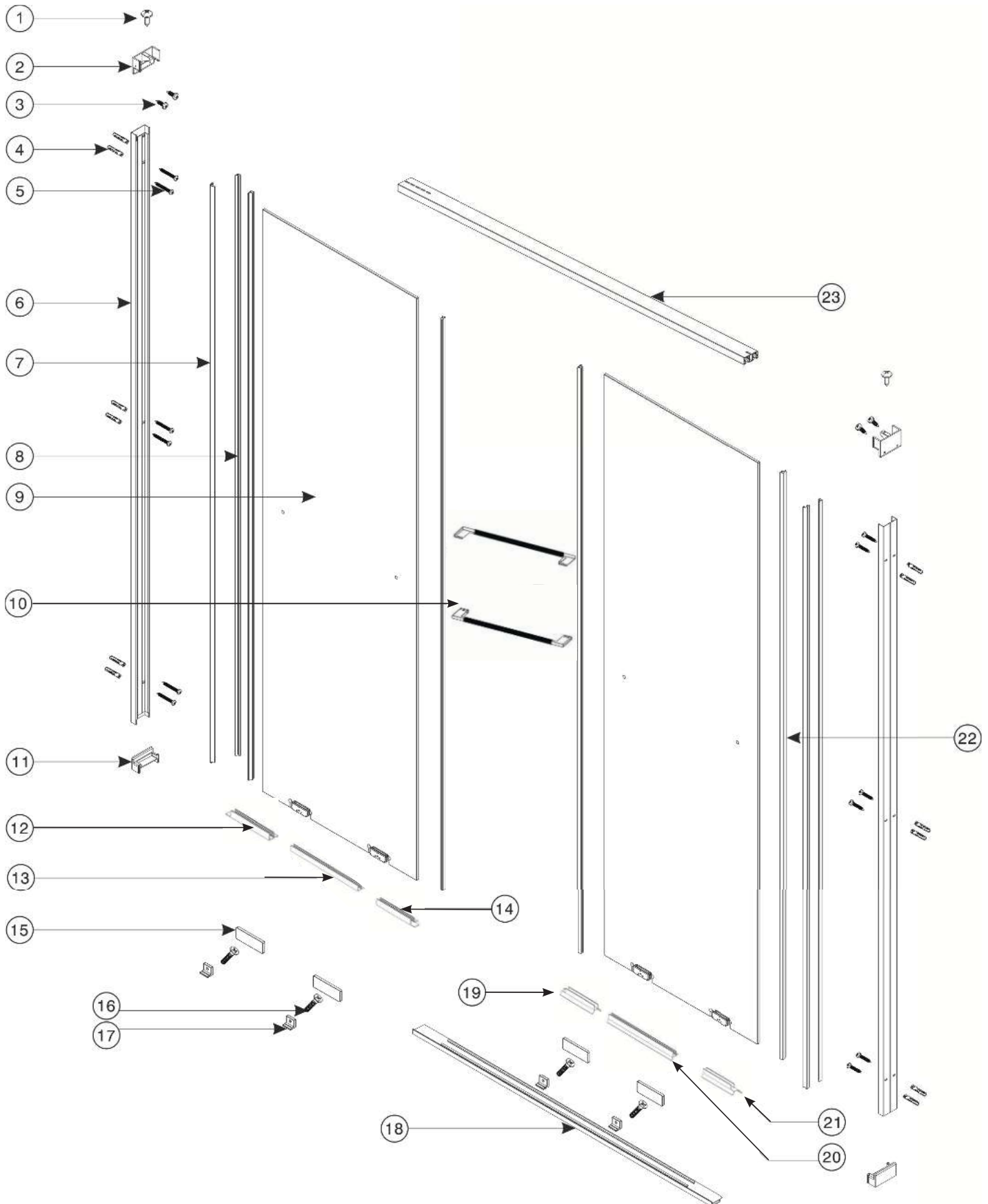



#	Part	Nom de la pièce	Pieza	Qt Cant.
1	Screw 4mmx12mm PAN	Vis 4mmx12mm PAN	<i>Tornillo 4mmx12mm PAN</i>	2
2	Header bracket	Support de rail	<i>Soporte de riel</i>	2
3	Screw 4mmx6mm FLT PHI	Vis 4mmx6mm FLT PHI	<i>Tornillo 4mmx6mm FLT PHI</i>	4
4	Wall anchor	Ancrage mural	<i>Anclaje mural</i>	12
5	Screw 4mmx30mm PAN	Vis 4mmx30mm PAN	<i>Tornillo 4mmx30mm PAN</i>	12
6	Wall jamb	Montant mural	<i>Montante mural</i>	2
7	Short wall jamb gasket	Joint court du montant mural	<i>Junta corta del montante mural</i>	2
8	Long wall jamb gasket	Joint longue du montant mural	<i>Junta larga del montante mural</i>	2
9	Panel assembly	Assemblage de panneau	<i>Ensamble del panel</i>	2
10	Handle	Poignée	<i>Manija</i>	2
11	Threshold bracket	Support de seuil	<i>Soporte del umbral</i>	2
12	Exterior wall jamb gasket	Joint extérieur du montant mural	<i>Junta exterior del montante mural</i>	1
13	Exterior center gasket	Joint extérieur central	<i>Junta exterior central</i>	1
14	Exterior overlap gasket	Joint extérieur du chevauchement	<i>Junta de superposición exterior</i>	1
15	Roller cover	Couverture des roulettes	<i>Cubierta del rodamiento</i>	8
16	Screw M3x6mm	Vis M3x6mm	<i>Tornillo Vis M3x6mm</i>	4
17	Anti-jump bracket	Support anti-saut	<i>Soporte antisalto</i>	4
18	Threshold	Seuil	<i>Umbral</i>	1
19	Interior overlap gasket	Joint intérieur du chevauchement	<i>Junta de superposición interior</i>	1
20	Interior centre gasket	Joint intérieur central	<i>Junta interior central</i>	1
21	Interior wall jamb gasket	Joint intérieur du montant mural	<i>Junta interior del montante mural</i>	1
22	Panel gasket	Joint du panneau	<i>Junta del panel</i>	4
23	Header	Rail	<i>Riel</i>	1
24	Allen keys	Clés allen	<i>Llaves allen</i>	2

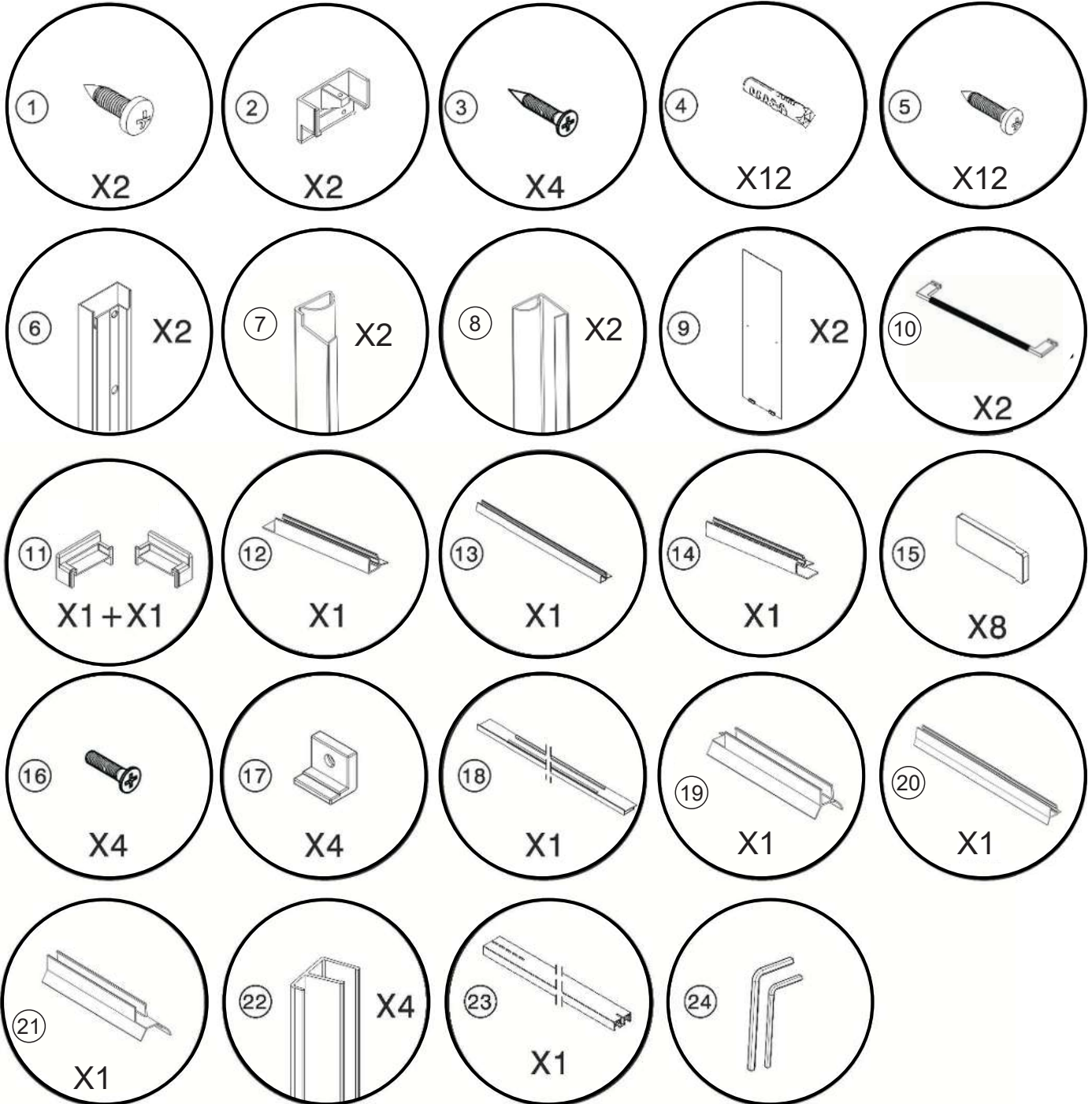

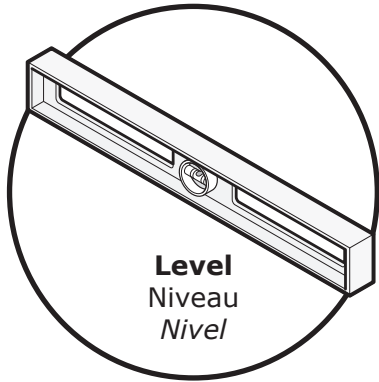

Level
Niveau
Nivel



Pencil
Crayon
Lápiz

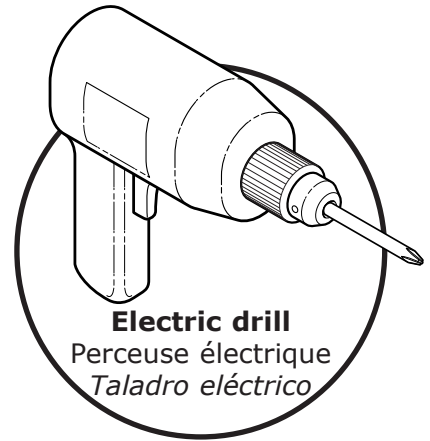

Electric drill
Perceuse électrique
Taladro eléctrico



Clear silicone sealant
Silicone claire
Sellador de silicona
transparente



Rubber mallet
Maillet en caoutchouc
Mazo de caucho



1/4" ceramic drill bit
Mèche à céramique
de 1/4 po.
Broca para
ceramica

1/8" drill bit
Mèche de 1/8 po.
Broca de 1/8"

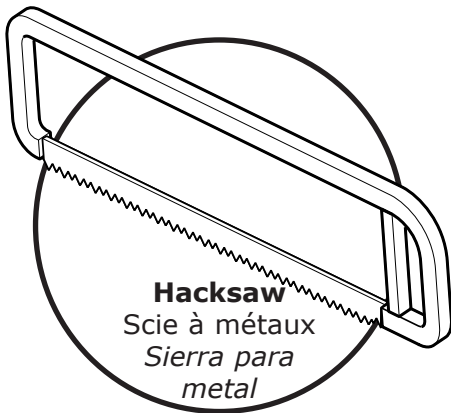

Hacksaw
Scie à métaux
Sierra para
metal

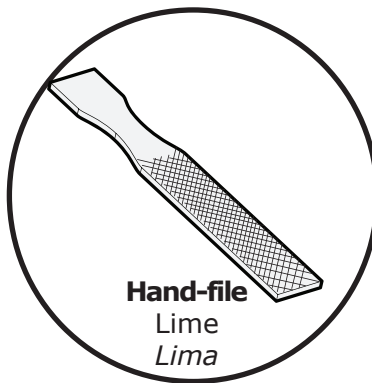

Hand-file
Lime
Lima

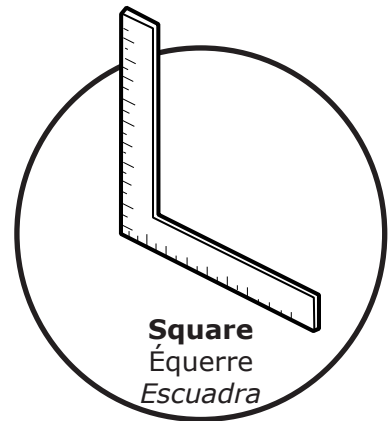

Square
Équerre
Escuadra

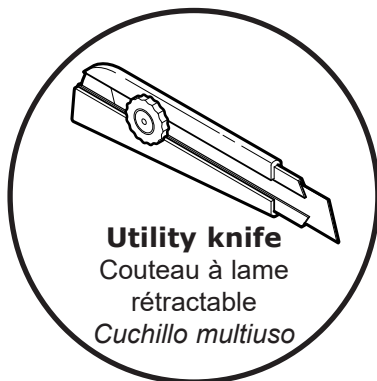

Utility knife
Couteau à lame
rétractable
Cuchillo multiuso



Security equipment
Équipement de sécurité
Equipamiento
de seguridad

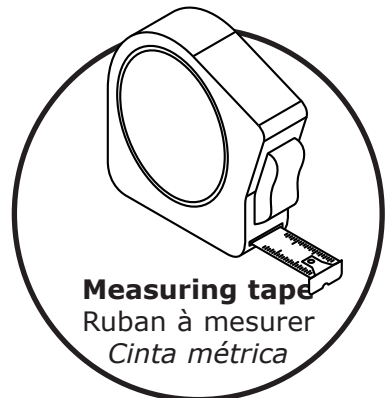

Measuring tape
Ruban à mesurer
Cinta métrica



A

Make sure that the door and panel fit within the shower enclosure. To do so, measure the height and width of the shower threshold, and compare these measures to those of the door.

S'assurer que la porte s'ajuste bien par rapport à l'ouverture prévue pour la douche. Pour ce faire, il faut mesurer la hauteur et la largeur du seuil et comparer les mesures prises à celles dans l'encadré ci-dessous.

Asegúrese de que la puerta se ajuste a la cabina de ducha. Mida la altura y el ancho del umbral de ducha y compare esas medidas con las de la puerta.

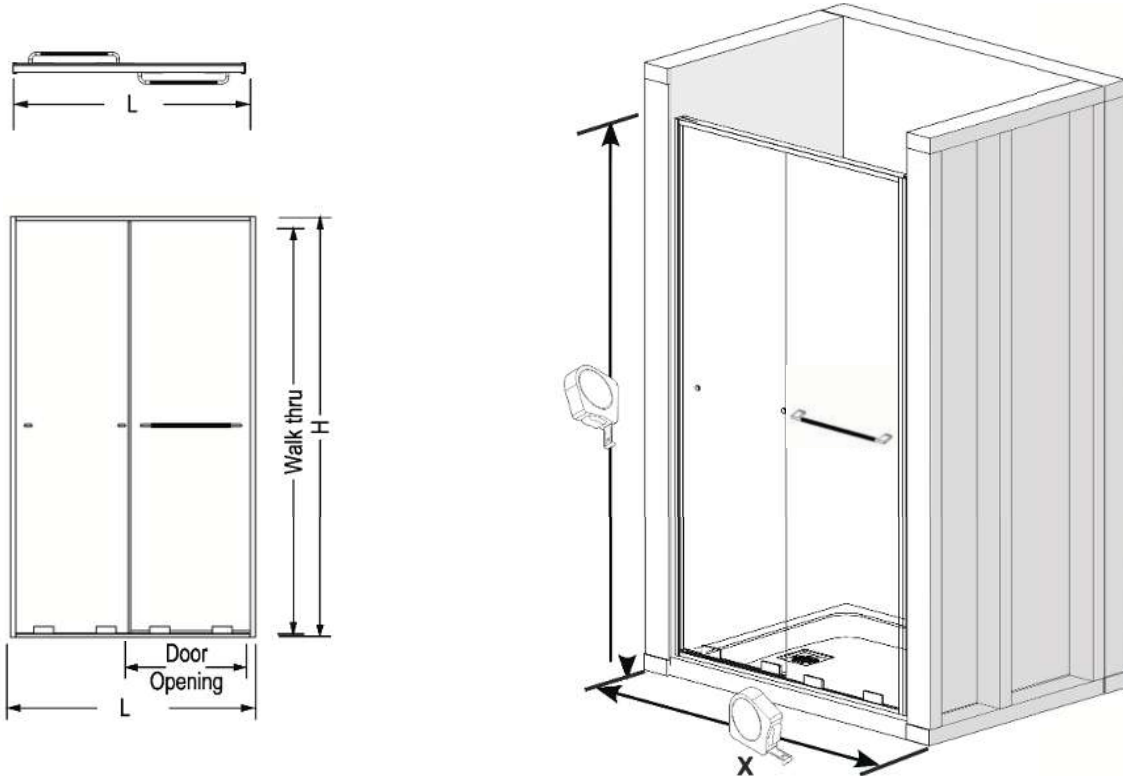

DESCRIPTION	H	L Adjustable	Door opening
SOLANI(48"x79.75")	79.75"	45"-47.5"	21.15"
SOLANI(60"x79.75")	79.75"	57"-59.5"	27.13"



B

Horizontal and vertical studs are needed in order to install the water fixtures. See appropriate installation guides.

Des 2' x 4' horizontaux et verticaux doivent être installés pour l'installation des composantes de robinetterie. Voir les guides d'installation correspondants.

Se necesitan montantes horizontales y verticales para poder instalar los accesorios de plomería. Ver las guías de instalación apropiadas.



C

A two person installation is recommended.

Une installation par deux personnes est recommandée.

Se recomienda realizar la instalación entre dos personas.





D

Double the studs (2x4) where the wall jambs will be installed.

Doubler les montants de bois (2x4) là où les montants muraux seront installés.

Duplicar los montantes (2x4) en los lugares en los que se instalarán las jambas murales.

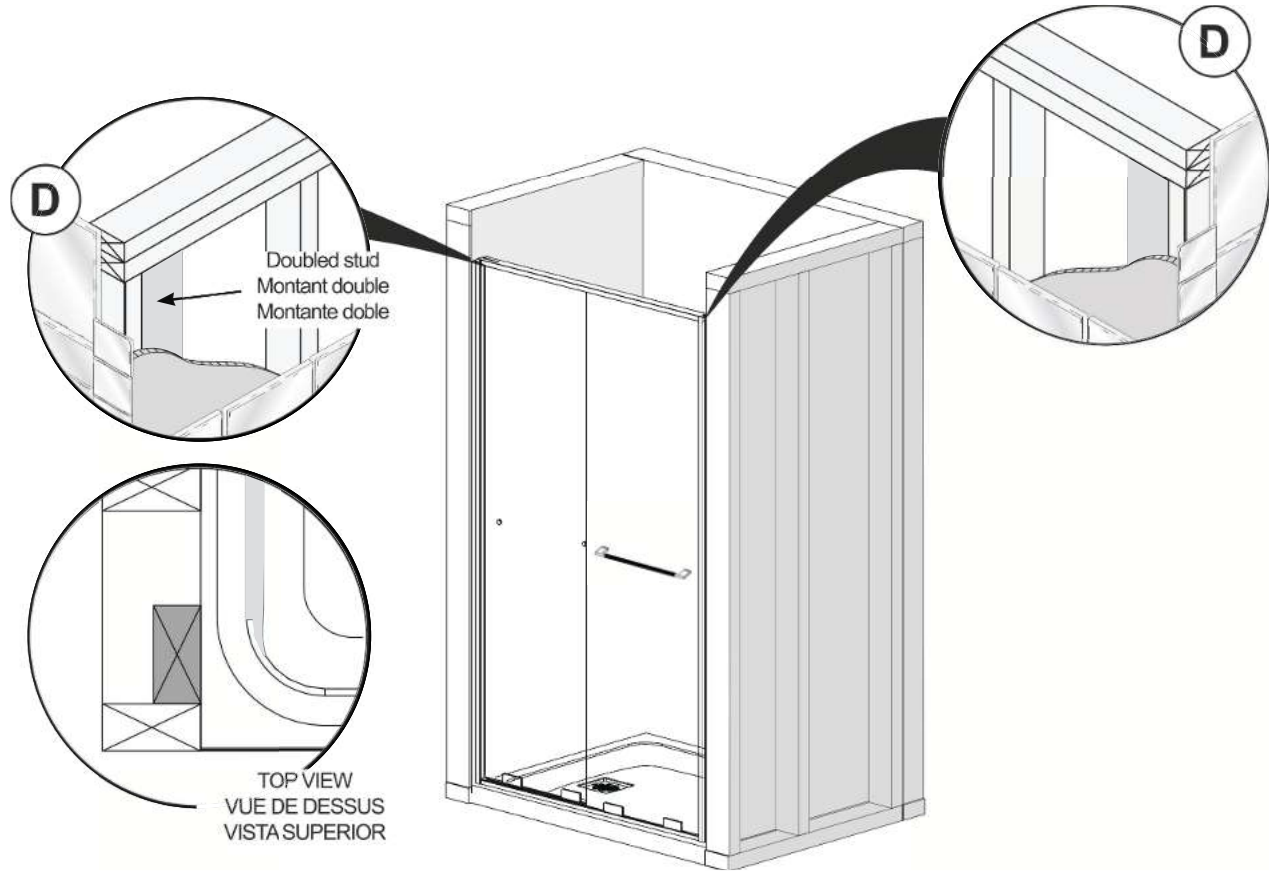

E

Verify that the shower base is perfectly leveled.

Vérifier que la base est parfaitement de niveau.

Verificar que la base de ducha esta completamente nivelada.

E

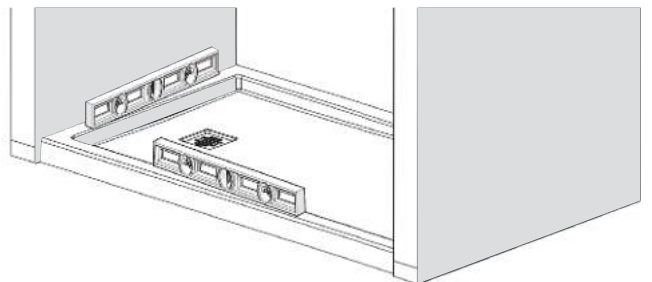

F

Place cardboard at the bottom of base to protect finish.

Placer le carton à l'intérieur de la base pour protéger la finition.

Coloque el cartón en la parte inferior de la base para proteger el acabado.

F

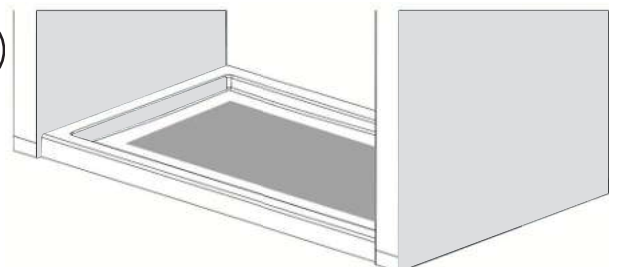



1

Parts required:
Pièces requis:
Partes requeridas:

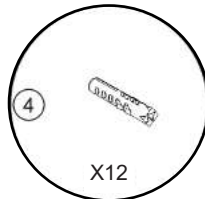

1. Place wall jambs on threshold brackets. Level the wall jambs back against the wall. Mark the position of the fastening holes on the shower wall. Remove the wall jambs. Drill the holes with a 1/8" drill bit. [For ceramics and wall anchors always use a ceramics 1/4" drill bit]. Apply silicone inside the holes. *Insert the wall anchors if there is no stud behind the wall jamb Remove wall jambs and threshold brackets.

1. Placer les montants muraux sur les supports du seuil. Mettre de niveau les montants muraux contre le mur. Marquer la position des trous de fixation. Retirer les montants. Percer les trous avec une mèche de 1/8 po. [Pour de la céramique et des ancrages muraux, toujours prendre une mèche à céramique 1/4 po.]. Appliquer du silicone dans les trous. *Insérer des ancrages muraux s'il n'y a pas de montants en bois à l'arrière des montants muraux. Enlever les montants muraux et les supports du seuil.

1. Colocar los montantes murales sobre los soportes del umbral. Nivelar los montantes murales contra la pared. Marcar la posición de los orificios de fijación de los soportes. Retirar los soportes. Taladrar los agujeros con una broca de 1/8". [Para taladrar azulejos y anclajes de pared, use siempre una broca para cerámica de 1/4"]. Aplique silicona dentro de los agujeros. *Inserte los anclajes de pared, si no hay montantes detras de los montantes murales. Quitar los montantes murales y los soportes del umbral.

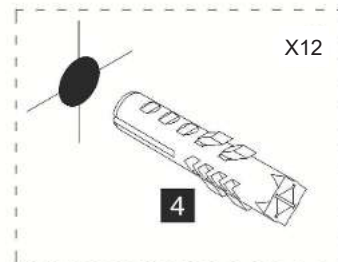
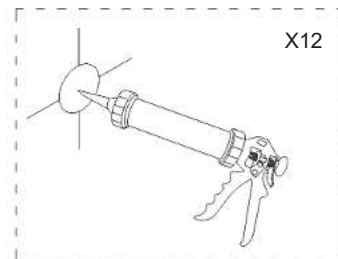
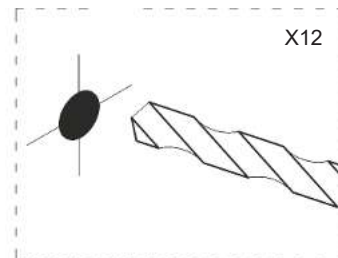
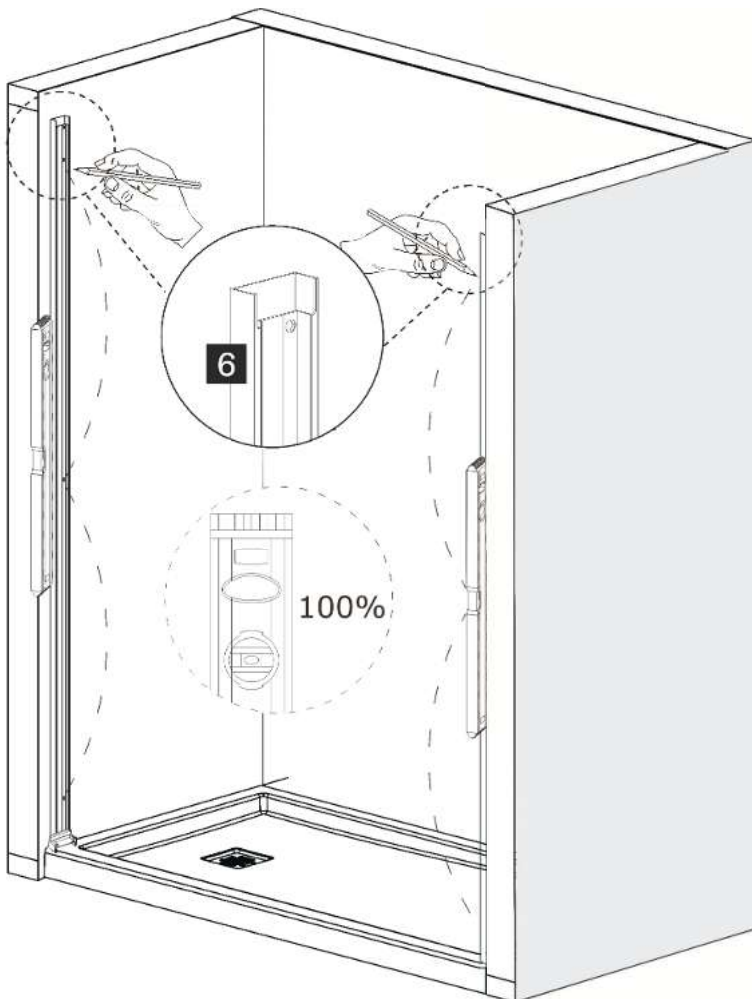



2

Parts required:
Pièces requis:
Partes requeridas:

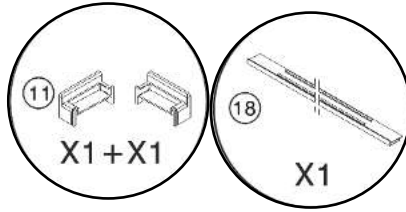

2. Measure the distance between the shower walls and remove 3/16" from that measure. If the opening is under 46.3 in wide, cut both ends equally. Ensure the threshold and threshold brackets are square and aligned to the front of the base.

2. Mesurer la distance entre les murs de douche et enlever 3/16 po de cette mesure. Si l'ouverture est en dessous de 46.3 po, couper la même longueur des deux côtés. Assurez-vous que les supports du seuil et le seuil sont alignés avec l'avant de la base.

2. Medir la distancia entre los muros de la ducha y restar 3/16" de esa medida. Si la apertura está por debajo de 46.3 pulgadas, corte la misma longitud de ambos lados. Asegurarse de que los soportes de esquina y el conjunto del umbral estén alineados y paralelos al frente de la base.

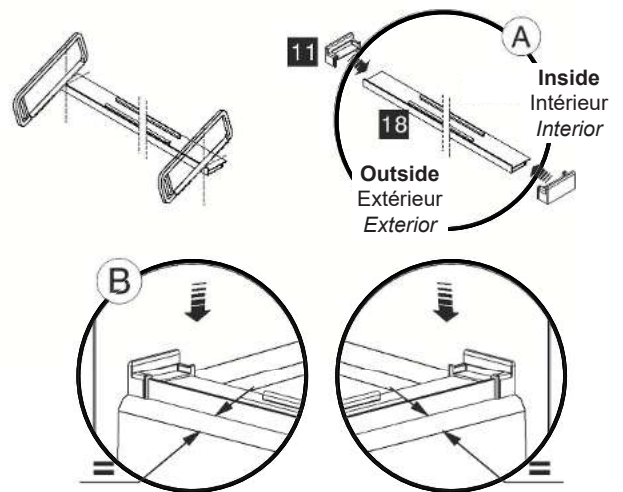
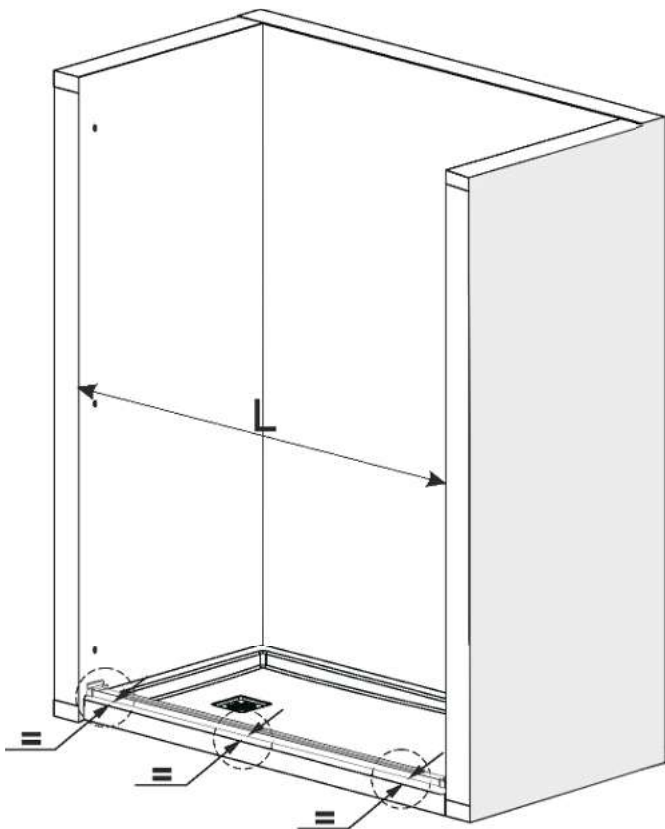



3

Parts required:

Pieces requis:

Partes requeridas:

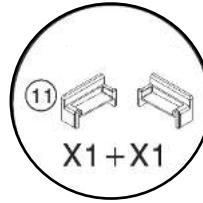
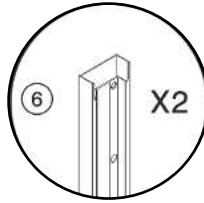
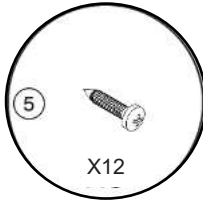
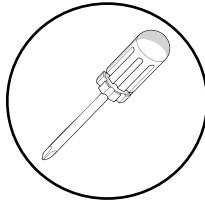

3. Insert wall jambs onto threshold brackets. Ensure they are level and fasten the wall jamb using the screws provided. Do not fasten the top two holes.

3. Insérer les montants muraux sur les supports du seuil. Assurez-vous qu'ils sont de niveau, et fixer le montant mural utilisant les vis fournis. Ne fixer pas les deux trous d'en haut.

3. Inserte los montantes de la pared en los soportes del umbral. Asegúrese de que estén nivelados y fije el montante de la pared utilizando los tornillos proporcionados. No fije los dos agujeros de la parte superior.

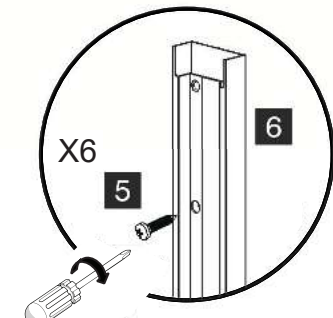
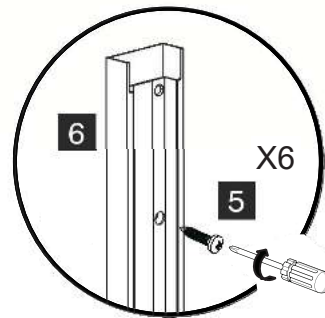
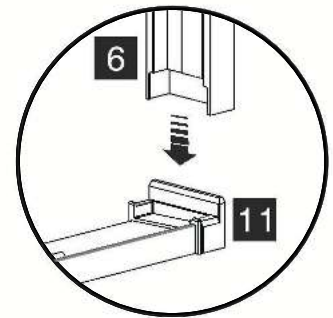
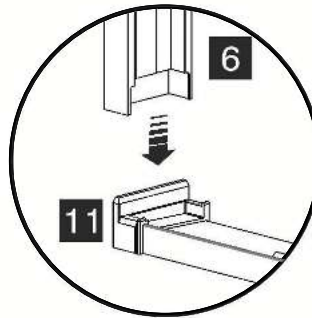
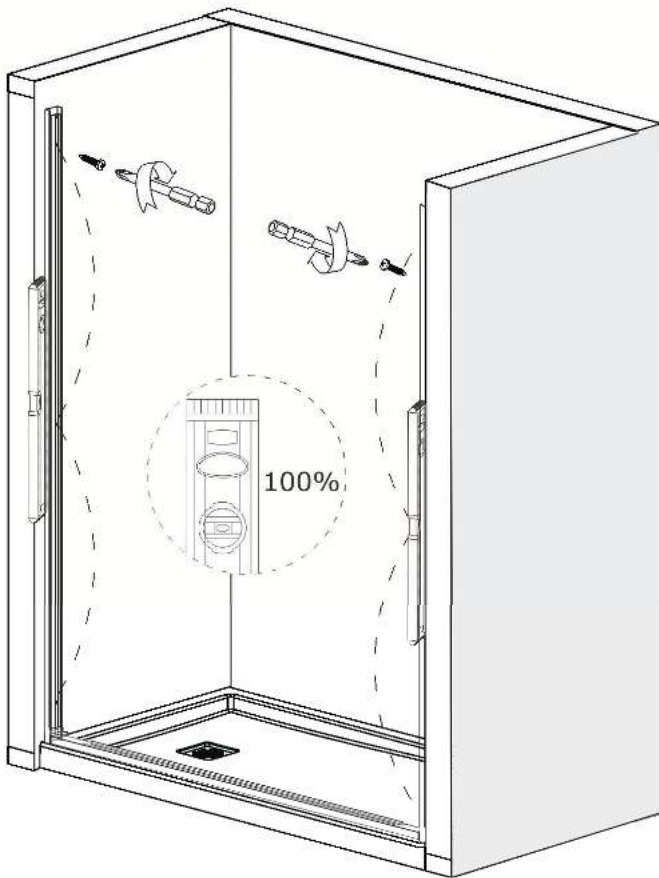



4

Parts required:

Pieces requis:

Partes requeridas:

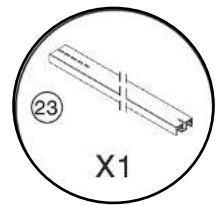
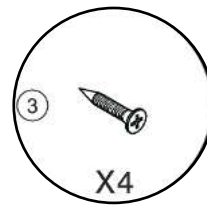
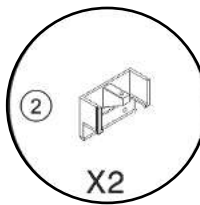
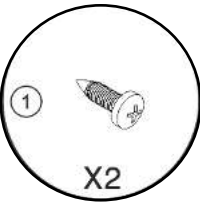
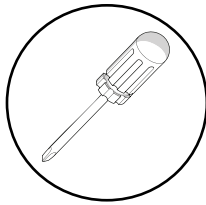

4. Measure the top of the opening of the shower enclosure and remove 3/16" from that measurement. Cut the header to length. If the opening is under 46.3", cut both ends of the header equally. Insert the header brackets into the header and place the header assembly onto the wall jambs. Fasten the header in place using the screws provided. Fasten the header to the header brackets using the screws provided.

4. Mesurer la distance entre les murs de la douche et enlever 3/16 po de cette mesure. Couper le rail à la mesure prise précédemment. Si l'ouverture est en dessous de 46.3 po, couper des deux côtés également. Insérer les supports du rail dans le rail et placer l'assemblage sur les montants muraux. Fixer l'assemblage utilisant les vis fournies. Fixer le rail aux supports du rail utilisant les vis fournis.

4. Medir la distancia entre las paredes de la ducha y reste 3/16 de pulgada de esa medida. Corte el riel según la medida tomada previamente. Si la apertura es inferior a 46.3 pulgadas, cortar por ambos lados de manera igual. Insertar los soportes del riel en el riel y colocar el conjunto sobre los montantes de la pared. Fijar el conjunto utilizando los tornillos proporcionados. Fijar el riel a los soportes del riel utilizando los tornillos proporcionados.

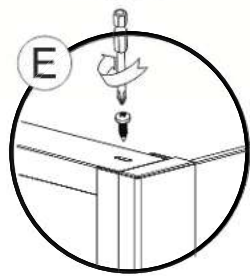
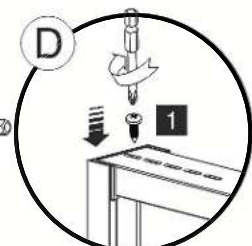
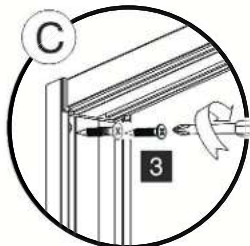
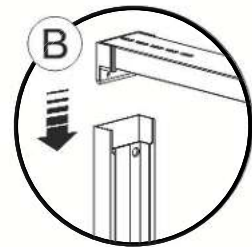
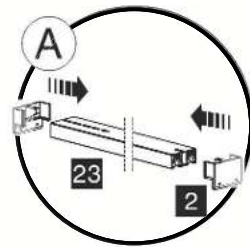
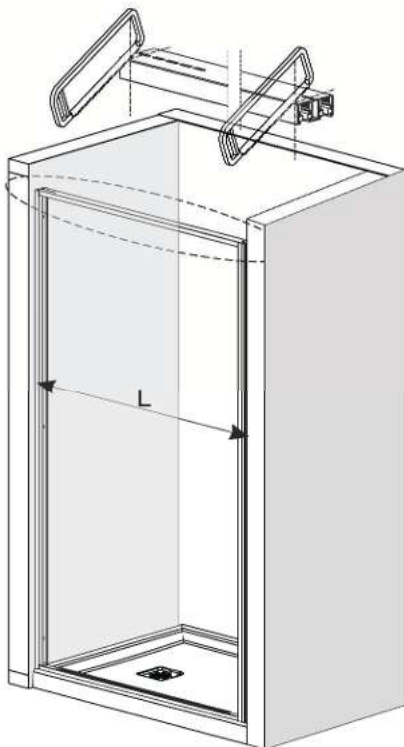



5

Parts required:

Pieces requis:

Partes requeridas:

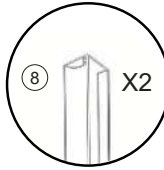
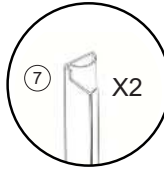

5. Remove tape backing on wall jamb gaskets and apply to the wall jambs

5. Retirez le ruban adhésif sur les joints des montants muraux et appliquez-les sur les montants muraux

5. Retire la cinta protectora de las juntas de las jambas de la pared y aplíquela en las jambas de la pared.

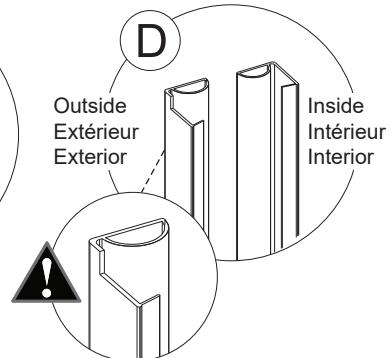
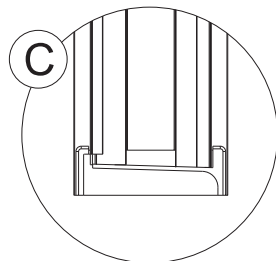
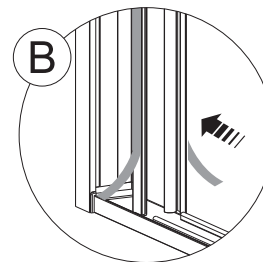
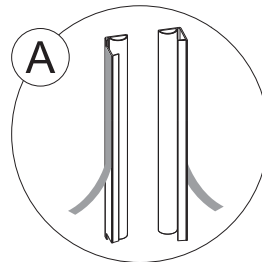
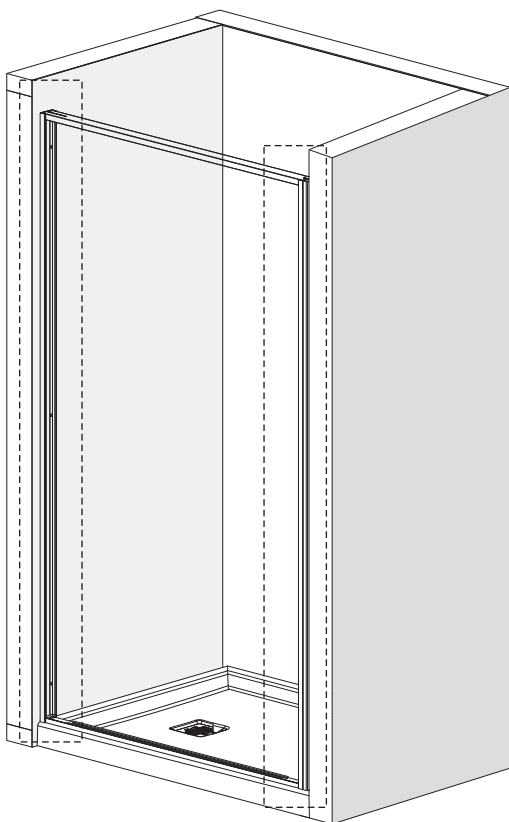



6

Parts required:
Pièces requis:
Partes requeridas:

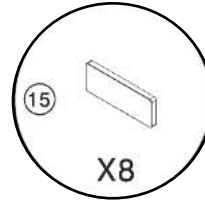
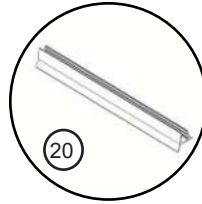

X8

6. Place decorative caps over rollers, then place middle gasket on both doors. Remove the decorative caps. The middle gasket will not be aligned unless the decorative caps are installed first.

6. Placez les capuchons décoratifs sur les rouleaux, puis placez le joint central sur les deux portes. Retirez les capuchons décoratifs. Le joint central ne sera pas aligné si les capuchons décoratifs ne sont pas installés en premier.

6. Coloque las tapas decorativas sobre los rodillos y luego la junta central en ambas puertas. Retire las tapas decorativas. La junta central no quedará alineada a menos que se instalen primero las tapas decorativas.

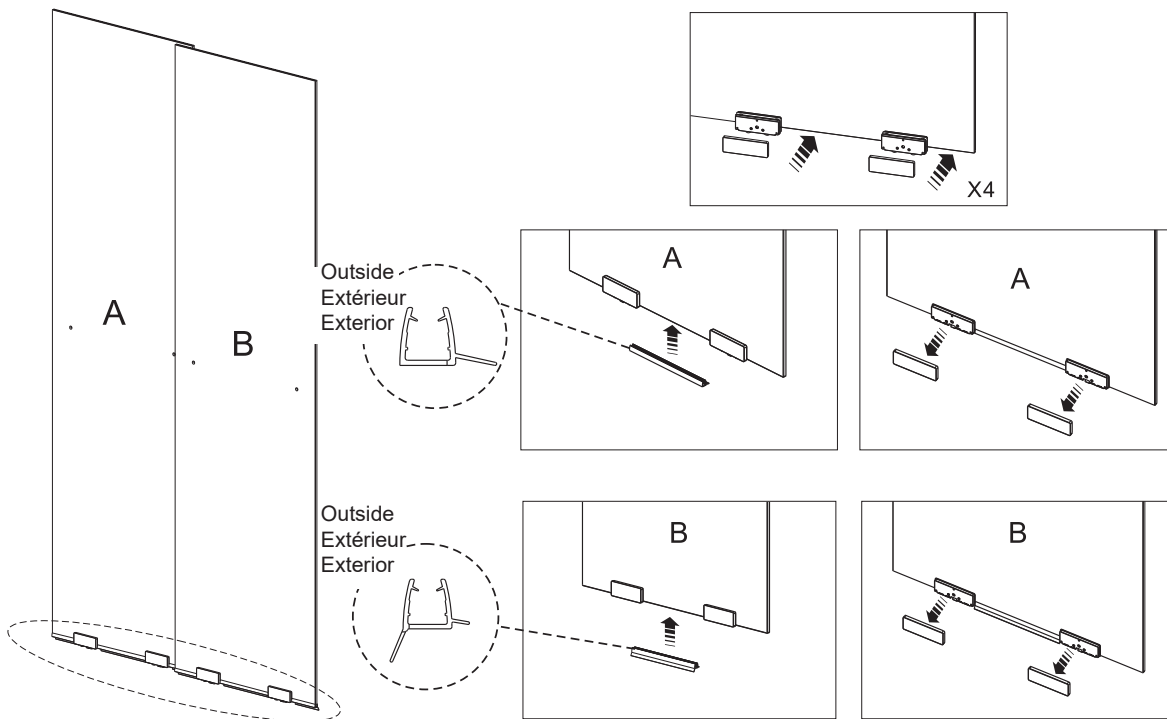



7

Parts required:
Pièces requis:
Partes requeridas:

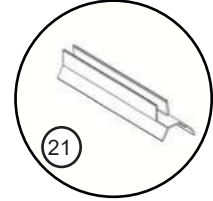
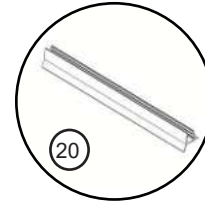
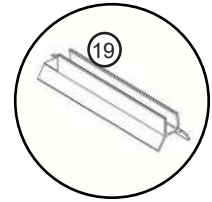
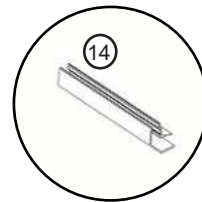
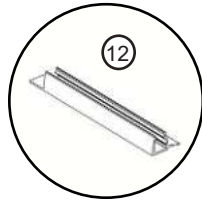

7. Place the gaskets as shown on the underside of the doors.
7. Placer les joints tel que montré sur l'en-dessous des portes.
7. Coloque las juntas tal como se muestra en la parte inferior de las puertas.

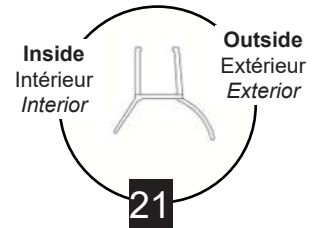
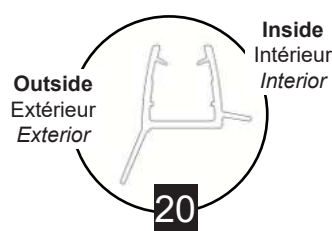
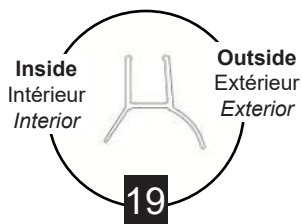
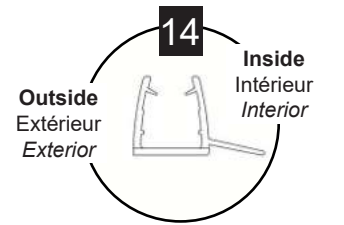
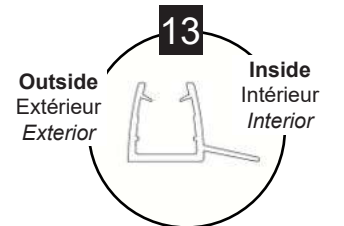
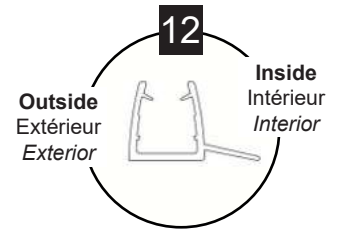
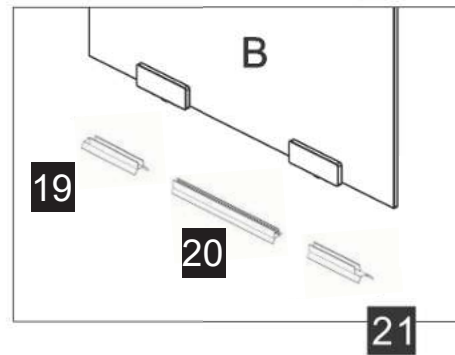
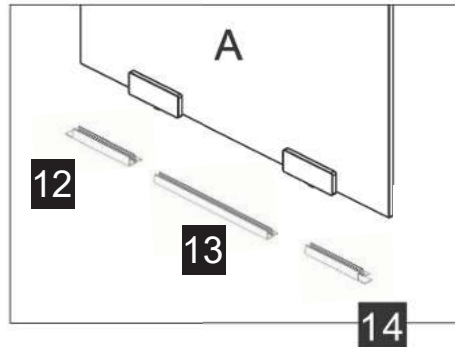
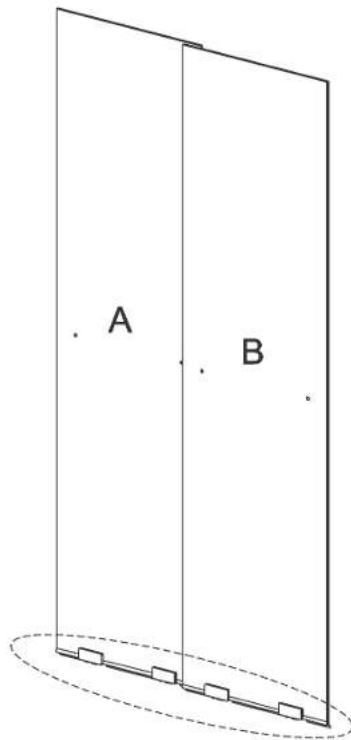



8

8. Place both doors inside the shower, in the correct orientation. Lift the outside door and align the top with the channel in the rail, then align the bottom of the door with the rail on the threshold. Repeat with the interior door. The lip of the outside door's gasket should be inside the threshold rail

8. Placer les deux portes à l'intérieur de la douche, dans la propre orientation. Levez la porte extérieure et l'aligner avec le canal dans le rail, puis aligner les roulettes sur l'en dessous de la porte avec le rail sur le seuil. Répétez avec la porte intérieure. La lèvre du joint de la porte extérieure doit être à l'intérieur du rail de seuil

8. Colocar las dos puertas dentro de la ducha, en la orientación correcta. Levantar la puerta exterior y alinéela con el canal en el riel, luego alinear las ruedas en la parte inferior de la puerta con el riel en el umbral. Repetir el proceso con la puerta interior. El borde de la junta de la puerta exterior debe estar dentro del riel del umbral.

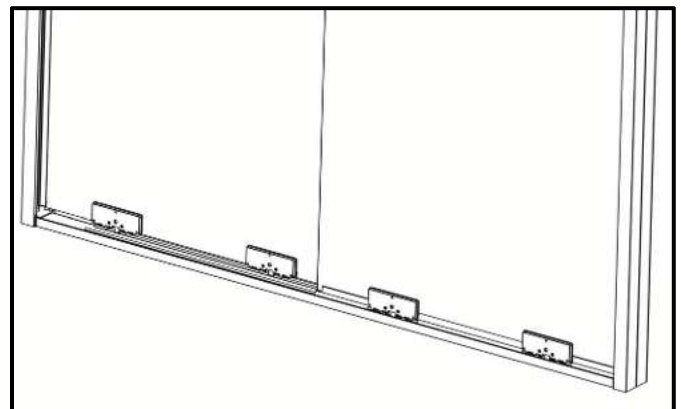
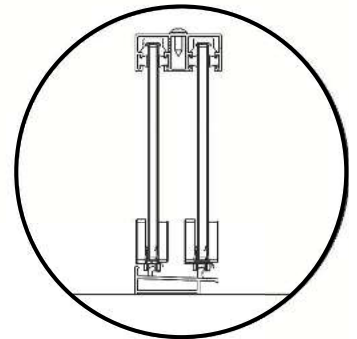
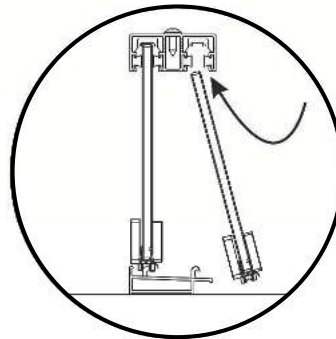
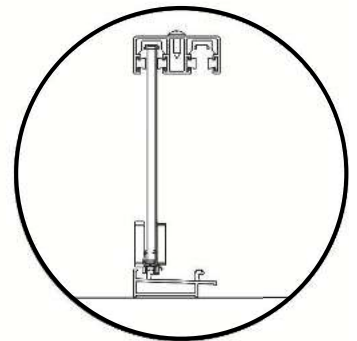
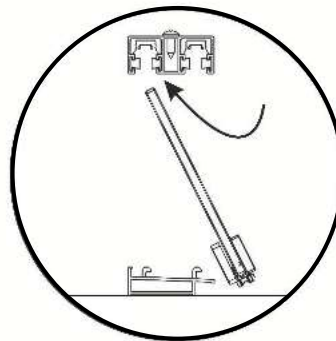
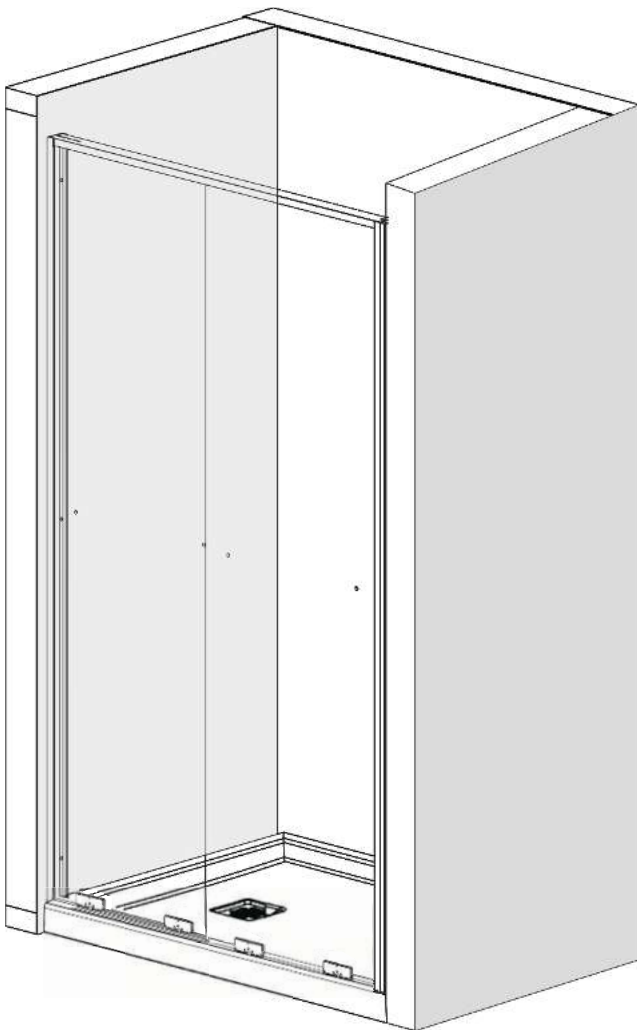
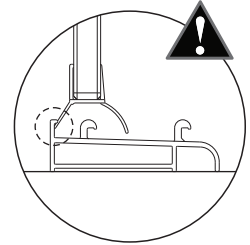



9

Parts required:
Pièces requis:
Partes requeridas:

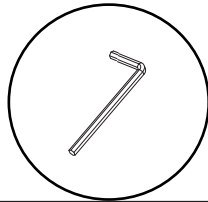

9. Level shower doors by tightening or loosening the levelling screw in the rollers. Add vertical gaskets to door panels.

9. Assurez-vous que les portes sont de niveau en serrant ou desserrant la vis nivelant des roulettes. Ajoutez les joints verticaux aux panneaux

9. Asegurarse de que las puertas estén ni veladas ajustando o aflojando el tornillo de nivelación de las ruedas. Añadir juntas verticales a los paneles de las puertas

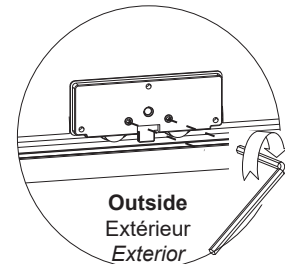
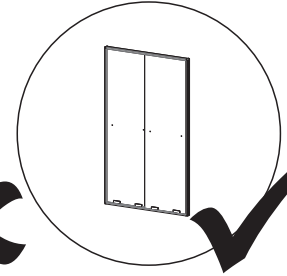
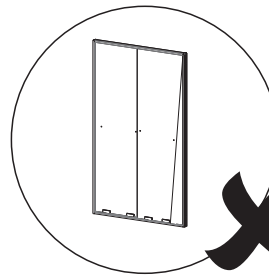
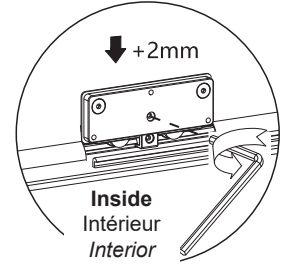
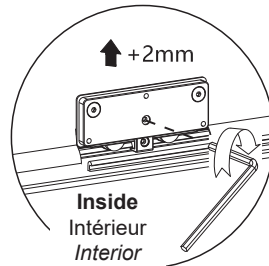
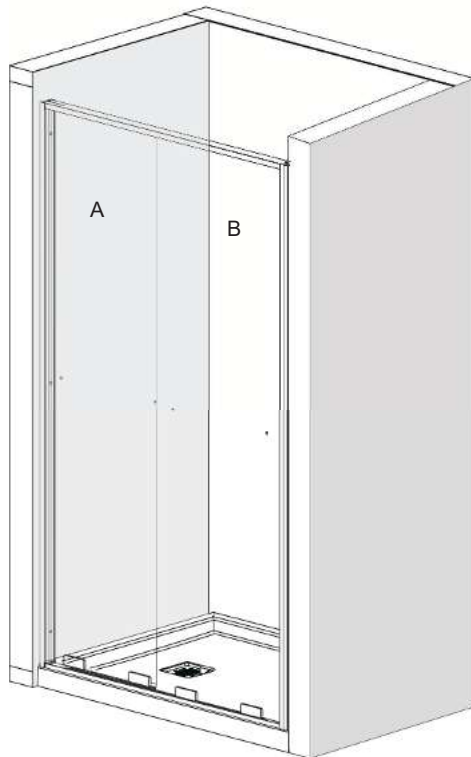
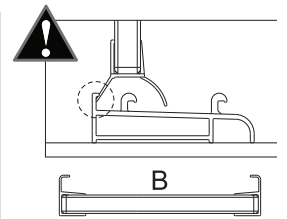
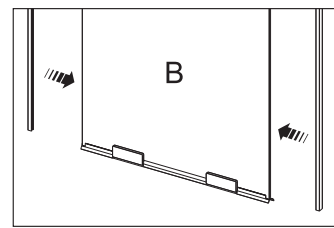
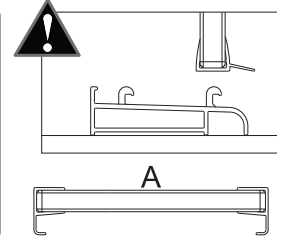
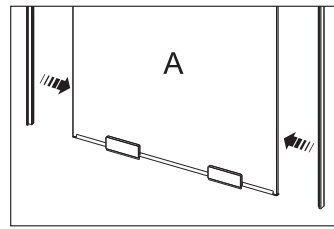



Produits Neptune

10

Parts required:
Pièces requis:
Partes requeridas:

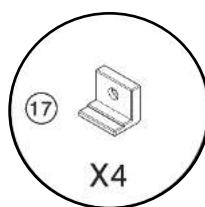
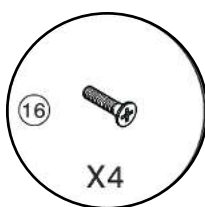
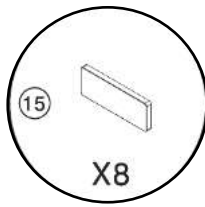
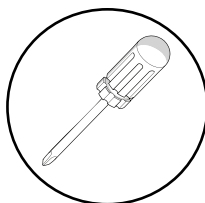

10. Screw on anti-jump bracket. Add caps to rollers. Assemble handle onto door as shown.
10. Fixez le support anti-saut. Ajoutez les capuchons aux roulettes. Assemblez la poignée sur les ports tel que montré.
10. Fijar el soporte antisalto. Añadir las tapas a las ruedas. Ensamblar la manija en las puertas tal como se muestra.

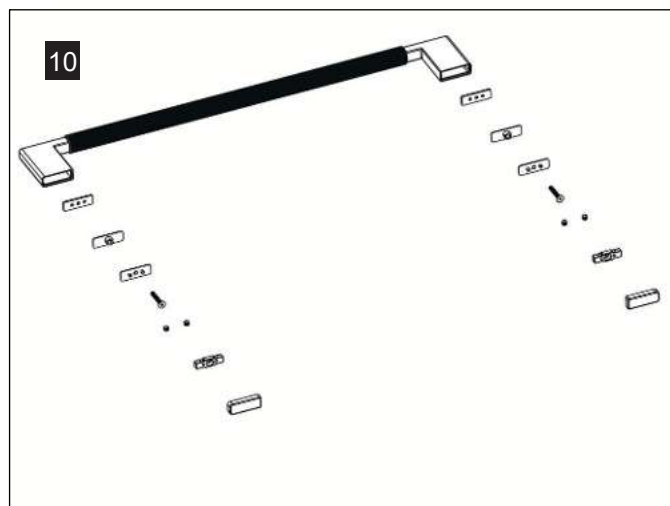
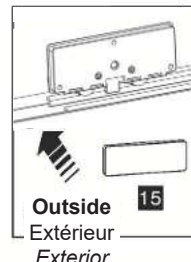
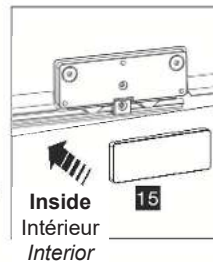
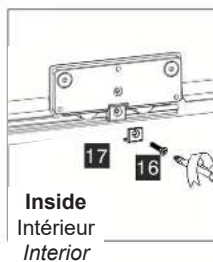
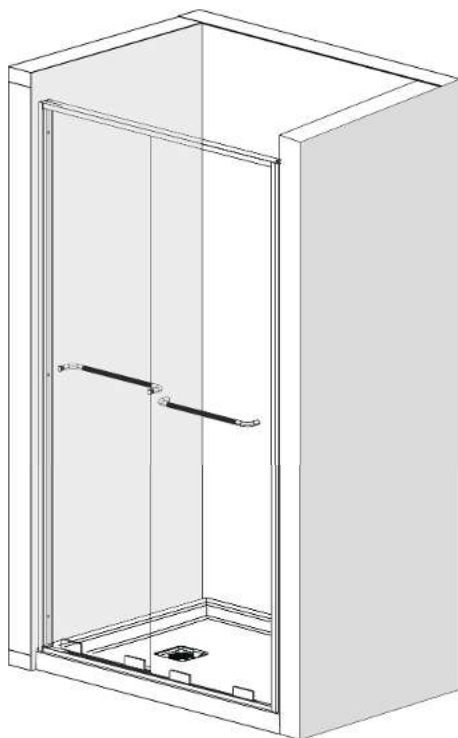

11

Parts required:
Pièces requis:
Partes requeridas:



Produits Neptune

9. On the outside of the shower and on both sides of the door guide, apply a bead of silicone as shown.

9. À l'extérieur de la douche et des deux côtés du guide de porte, appliquer du silicone tel qu'illustré.

9. Al exterior de la ducha y en ambos lados de la guía de la puerta, aplicar sellador de silicona como se muestra.



Wait 24 hours before using the shower.
Attendre 24 heures avant d'utiliser la douche.
Espere 24 horas antes de utilizar la ducha.

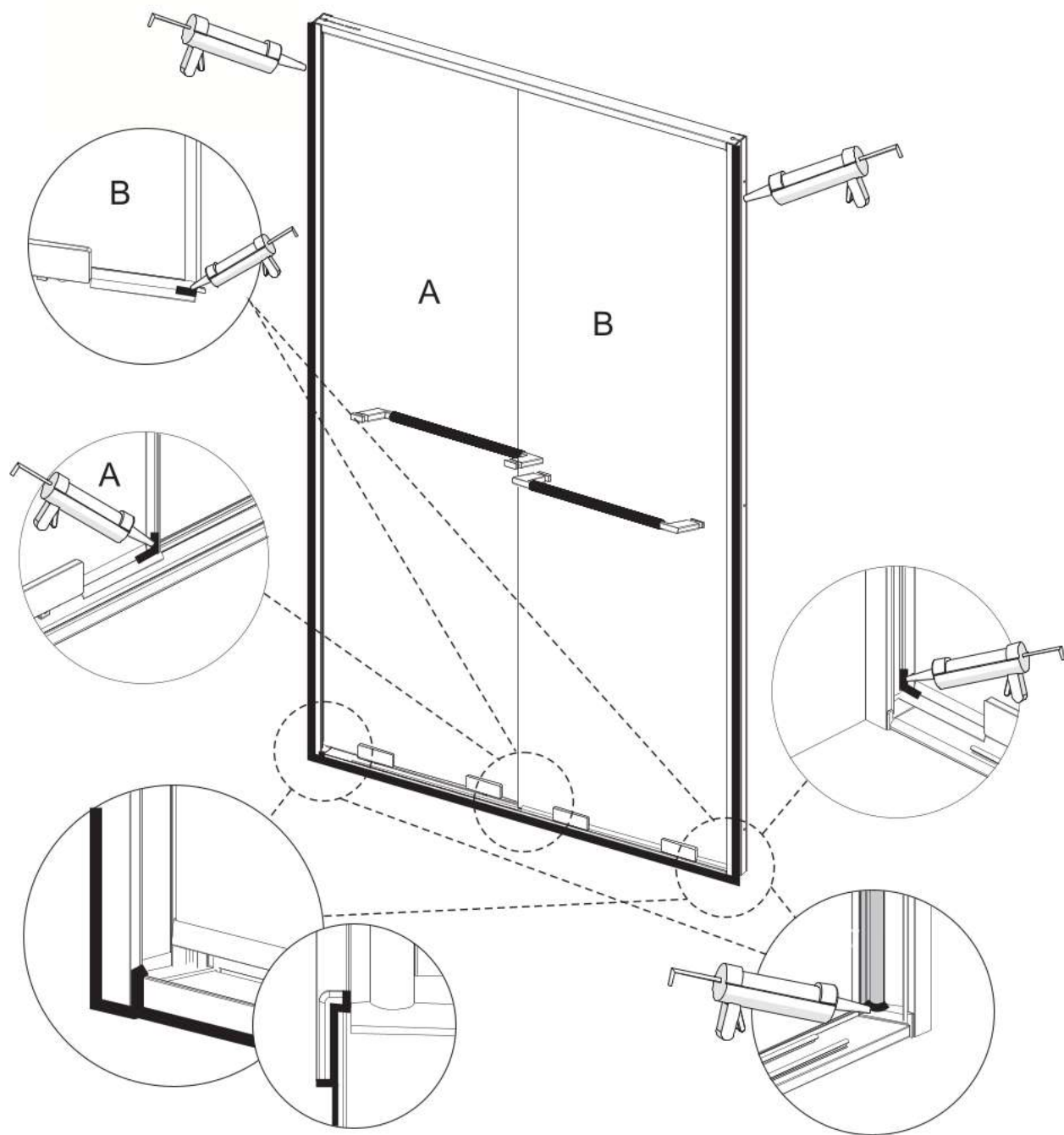



MAINTENANCE | ENTRETIEN | MANTENIMIENTO

Check me!
Cochez-moi!
Marcarme!



Right after installation
Juste après l'installation
Justo después de la instalación

- 1. Open the door and verify it closes seamlessly. Also verify that the gap when opened on bottom and top is equal. If not adjust the screws of the rollers to lift or lower the door.**

Ouvrir la porte et vérifier qu'elle se ferme parfaitement. Vérifier égale ment que l'écart lorsqu'il est ouvert en bas et en haut est égal. Sinon, ajuster les vis des roulettes pour lever ou abaisser la porte.

Abrir la puerta y verificar que cierre a la perfección. También verificar que la separación cuando se abre sea igual en la parte inferior y superior. Si no, ajustar los tornillos de los rodamientos para subir o bajar la puerta.

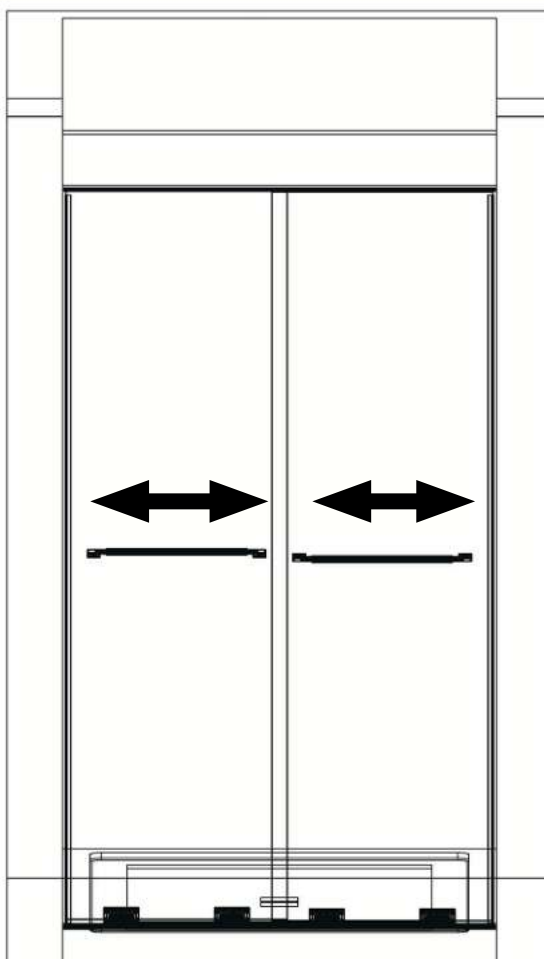



MAINTENANCE | ENTRETIEN | MANTENIMIENTO

Check me!
Cochez-moi!
Marcarme!



Every 6 months
Chaque 6 mois
Cada 6 meses

2. Make sure all gaskets and caps are installed. Also fasten any loose screws (handles, door frame).

S'assurer que tous les joints et les capuchons sont installés. De plus, serrer les vis desserrées (poignées, cadre de porte).

Asegurarse de que todas las juntas y la tapas estén instaladas. También apretar los tornillos sueltos (manijas, marco de puerta).

